

LONG TERM PERFORMANCE OF TOUGHENED GLASS INSULATORS ON AC AND DC TRANSMISSION LINES :

IMPROVEMENT, FIELD EXPERIENCE AND RECOMMENDATIONS

R. PARRAUD
////// Sediver (France) ////

H. PECLY
Electrovidro

~~~~~

Doc n° 13360

### ABSTRACT

Since the 50's, the development of the use of the toughened glass insulators has been increasing on all high voltage overhead lines, for AC up to 800 kV and for DC up to 600 kV.

The reliability of toughened glass insulators developed in France, their facility of minimum maintenance are some key factors of their success.

The good data on the AC and DC lines, on the behaviour of these toughened glass insulators in various and extreme conditions (temperature, humidity, pollution, lightning, ...) which are presented in the report, result from constant and permanent studies in laboratories, test stations and lines.

This report presents the work made on the materials associated with their manufacturing technology and their quality control.

The studies on the design to solve all problems which can be encountered in service such as pollution, hot line working ... are also presented.

From these studies, some basic recommendations are established to help the user to select reliable insulators according to their needs.

#### 1. The development of the toughened glass insulator

Insulators represent only a small part (a few per cent) of the cost of overhead lines. Nevertheless they play a crucial role both for the reliability of the line and the safety of people; the failure of only one element of an insulator string has very serious consequences.

Electrical energy transmission celebrated its centenary in 1983. The first insulators used were made of annealed glass. Since then, three important events occurred :

- In 1884, the production of non-porous porcelain suitable for outdoor high voltage insulation.
- In 1904, the design of the "cap and pin" or suspension insulator, nowadays the most widely used on power transmission lines.
- Since 1937, the toughening of soda-lime glass for the manufacture of insulators.

Each of these technical advances had primarily the purpose of improving the long term performance of the insulators.

More than 350 million SEDIVER - ELECTROVIDRO units in successful service at all voltages up to 800 kV AC and 500 kV DC in more than one hundred and twenty countries are operating in different and extreme climatic conditions.

For example, now, 3 out of every 4 insulators in service on both 800 kV AC and DC UHV transmission networks built in the last twenty years are toughened glass insulators developed by SEDIVER - ELECTROVIDRO.

This report will explain why the quality of the glass, the glass toughening process, the insulator design and quality control are the fundamental elements of the improvement of the quality of insulators, and show the practical advantages which result from the studies made by SEDIVER.

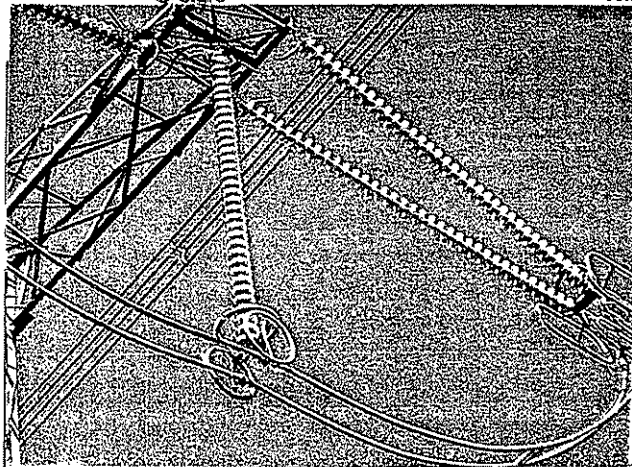

Fig 1 - 800 kV AC line (VENEZUELA)

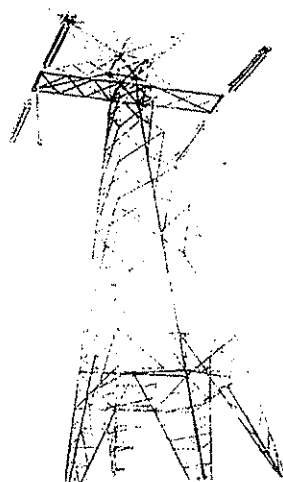

Fig. 2 - 600 kV DC line (BRAZIL)

## 2. The major interests of the toughened glass SEDIVER ELECTROVIDRO insulator

### 2.1 Long term performance and reliability :

The main advantages of the toughened glass insulator developed in FRANCE are :

- Indefinitely withstand the effects of time and the elements,
  - High mechanical strength and high residual strength
- Resistance to over-voltage impulses,
- Withstand effects of a large range of temperature (-50°C/+100°C) and mechanical overload conditions,
- Ability to resist to the stresses due to the environment like pollution, ice,
- No Ageing : test results after more thirty years of service operation on overhead lines are similar to the original test results on new insulators.

### 2.2 Negligible Maintenance

Maintenance is negligible and easy with toughened glass insulators for the following reasons :

- Very low rate of glass shell shattering on AC and DC lines, and railways lines, not affecting the quality of service and reducing the cost of maintenance,
- No risk that a dangerous internal flaw can exist in toughened glass insulator,
- Hot line maintenance in complete safety as toughened glass insulators can have no hidden defects,
- Survey by helicopter (total system control and safety is provided with toughened glass insulators which offer total visibility) (see figure 3 below).

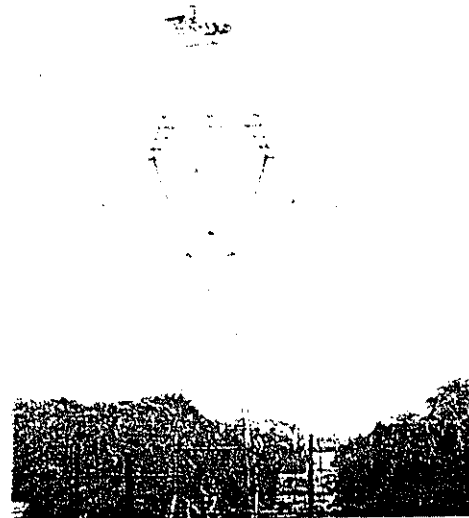

Fig. 3 - Helicopter line inspection

## 3. The improvements on the SEDIVER - ELECTROVIDRO glass insulators developed in FRANCE

### 3.1 Glass material :

Glass results from the complete melting of mineral oxides at very high temperature (> 1400 °C) and from a continuous controlled manufacturing processes (moulding and toughening).

#### 3.1.1 Glass composition :

The main components of the soda line glass are the following :

- |                                        |            |
|----------------------------------------|------------|
| • SiO <sub>2</sub>                     | 65 to 75 % |
| • CaO + MgO                            | 9 - 12 %   |
| • Na <sub>2</sub> O + K <sub>2</sub> O | 12 - 18 %  |

Two types of glass have been developed :

- Standard glass for HVAC insulators
- High resistivity glass for HVDC insulators which have to support specific electric stresses when compared with HVAC insulator (high voltage on single unit, uni-directional field, ...). The resistivity at 20°C of DC glass is 100 times higher than standard AC glass.

### 3.1.2 Glass structure - purity and homogeneity of the insulator glass :

The main objective to increase the quality of the glass corresponds to the elimination of any heterogeneity (inclusions) by the appropriate choice of the raw materials and furnace technology.

During moulding and toughening, no solid particles forms, nor does any crystallisation occur. The result is a completely uniform internal structure.

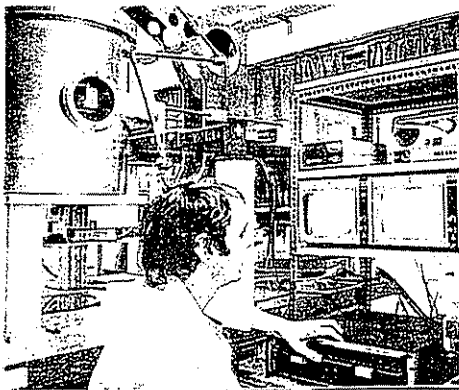

Fig. 4 - Laser Detection of inclusions



Fig. 5 - View of a detected inclusion

### 3.1.3 Glass transparency :

The transparency of the glass permits and facilitates the inspection of the internal quality of the shell. Special laser equipment for the detection of inclusions and glass defects on all types of glass shell has been developed by SEDIVER R & D to evaluate their harmfulness and to develop special treatment on line to eliminate the residual inclusions.

### 3.1.4 Main characteristics of the toughened glass insulator :

#### 3.1.4.1 Physical properties :

Ceramic materials like glass are considered as "brittle" materials which work only in the elastic phase up to failure. Their mechanical and thermal performances depend not only on the intrinsic properties of the material, but mainly only on the quality of their surfaces (external and internal) where micro-defects can lead to crack propagation under tensile stress.

The toughening process (see § 3.2.1.1) multiplies the mechanical performance of the glass by a factor of more than 5 compared to annealed glass [3].

The linear expansion coefficient of this glass insulators ( $9.10^{-6}$ ) is similar to that of the cement ( $10.10^{-6}$ ) and the metal parts ( $11.10^{-6}$ ) with which it is assembled.

The main physical properties are:

|                              |                              |
|------------------------------|------------------------------|
| Bulk Density                 | 2.4 to 2.6                   |
| Tensile strength             | 15 MPa                       |
| Young's Modulus              | 74000 MPa                    |
| Linear expansion coefficient | $9.10^{-6}/^{\circ}\text{C}$ |

#### 3.1.4.2 Electrical properties

Due the homogeneity, the electric strength of the glass is much higher than other materials used for insulators.

The intrinsic dielectric strength of glass is very high and consequently the resistance of toughened glass insulators to overvoltage, caused notably by lightning, is excellent [4,5].

The main electrical properties at 20°C are :

|                                      |                          |
|--------------------------------------|--------------------------|
| Relative Permittivity                | 7.3 to 7.6               |
| Dissipation factor $\text{tg}\delta$ | 150 to 600.( $10^{-4}$ ) |
| Dielectric strength (kV/cm)          | > 250                    |
| Resistivity $\Omega.m$               | 12 to $10^{14}$          |

The validity and universality of these standards have been verified for the most diverse and extreme conditions of use (low and high temperatures, pollution ...). [9]

Peculiar standards are used for DC applications.

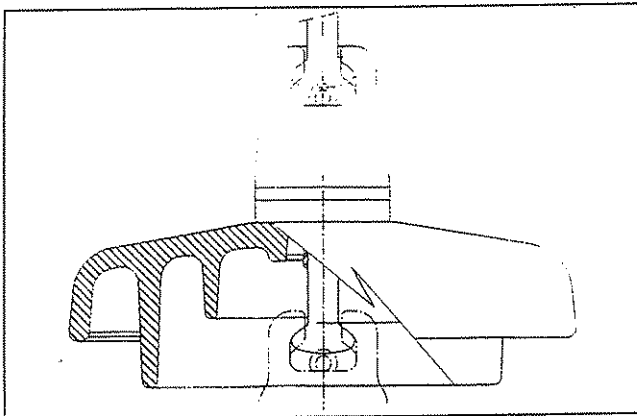

Fig. 9 - DC insulator

### 5. The most currently used IEC standards

The characteristics of the insulators depend not only on the materials but also of their design and their manufacturing process. The performance measured on a specimen of the insulating material alone is not always representative of the performance of the insulator. For this reason, the evaluation of the characteristics and reliability of the material is principally done by standardised tests relative to insulators representative of the technology used in industrial manufacturing. The following table summarises these tests.

TABLE : IEC Standards for cap and pin insulators

| General | Specific to cap and pin insulators |       | Special Tests         |      | Dimensions |
|---------|------------------------------------|-------|-----------------------|------|------------|
|         | Units or short string              | Sets  | Units or short string | Sets |            |
| 60      | 383-1                              | 383-2 | 437                   | 437  | 120        |
| 71      | 1325 <sup>1</sup>                  |       | 507                   | 507  | 305        |
|         |                                    |       | 575                   | 1467 | 372        |
|         |                                    |       | 797                   |      | 471        |
|         |                                    |       | 815                   |      |            |
|         |                                    |       | 1211                  |      |            |
|         |                                    |       | 1245                  |      |            |

<sup>1</sup> Note : IEC 1325 - Tests on toughened glass and ceramic insulators for D.C. systems.

This publication replaces IEC 438 and takes into account the reliability problems experienced in the past on D.C. lines. A selection of tests is given which ensure the higher reliability required for D.C. links and which takes into account the specific characteristics necessary for D.C. operation such as high resistivity, high purity dielectric materials [10, 11].

### 5.2 Standardised special tests

Several standard tests are available to evaluate the required level of long term reliability of suspension insulators :

- Evaluation of the long term reliability of the material by adjusting the amplification of the principal ageing factors : for example the thermal mechanical performance test (IEC 575), now introduced in IEC 383-1, in which thermal cycles (-30°C/+40°C), are combined with mechanical loading. The range of the variation of temperature can be more representative of the local conditions ; so for example, Canadian utilities specify a thermal mechanical test with a temperature range between -50°C/+50°C.
- Evaluation of the quality of the material by simulating occasional service stresses such as in IEC 1211 (which is based on the work of CIGRE 33), where lightning over-voltages are applied to check the resistance of insulators to puncture under steep front waves [5].
- Evaluation of the residual strength of damaged insulators - for example the residual mechanical strength test for toughened glass and ceramic insulators in IEC 797, in which the sheds of insulators are broken before carrying out mechanical failing load tests.

For the moment these tests are classified as type tests to deal effectively with the vital question of the in-service reliability; it is recommended to specify them as sample tests, in order to verify the consistency of the manufacturing. Some utilities already do so.

### 5.3 Special tests being standardised :

- Power arc tests on insulator sets (Draft IEC 1467). The goal of this test is to verify the ability of the complete insulator string with all its hardwares to withstand a power arc defined by its intensity and duration. In the past, such tests have been carried out in widely differing conditions and with varying acceptance criteria. This draft gives a standard type test method and mounting arrangements for power arc tests on insulator sets. It also takes into account pollution induced power arc flashover mechanisms and gives a general classification of damage resulting from the power arcs.

### 5.4 Recommendations for the choice of insulators and insulator strings for tropical environments

Tropical environments are characterised by a high humidity and a relatively hot temperature.

Natural pollution like dust from the ground (laterites, powdery soil) need to be taken into account in areas classified as clean by the inhabitants.



- EDF data [11]

Information is available on the EDF network where more than 9 millions of Sediver Toughened Glass insulators were used in 1991. For the preceding period of ten years the mean annual failure rate (for all reasons including external causes) of toughened glass insulators which had not affected the service were respectively :

- \* 0,51 per 10000 units for 400 kV lines
- \* 1,13 per 10000 units for 225 kV lines

- Hydro Quebec data [8]

Canada is characterised by a very large range of temperature variations.

The typical annual failure rates of toughened glass insulators installed on 735 kV lines of the James Bay project delivered in 1982 were :

- \* 3.4 per 10000 units after the first year of operation
- \* 2.1 per 10000 units after the second year of operation
- \* 1.4 per 10000 units after the third year of operation

At present, there are about 2,8 million toughened glass insulators installed on 735 kV AC lines.

Today many continuous improvements in the manufacturing process and in the controls to eliminate the pieces which contain a defect can be evaluated by service experience and show a negligible failure rate, lower than one unit per 10000 per year. This will be indicated by the latest data (0,3/10000 in 1985 after one year of operation for insulators delivered in 1984) and the following data for HVDC lines (see next §)

#### 4.1.2 Data on the performance of HVDC toughened glass insulators developed in France

Before the 80's, all cap and pin insulator type on HVDC line experienced a high failure rate which ranged between 10 to 30 times greater than that experienced on comparable HVAC lines [10].

Since 1985, high resistivity toughened glass insulators developed in France are in operation on HVDC lines up to  $\pm 600$  kV (BRAZIL).

Today, data from different utilities are available for up to nine years of service [11].

The annual failure rate (glass shattering) is lower than 0,1 per 10000 units from the date of operation of the HVDC lines in 1987.

This data is the result of the improvements of the quality of the glass and the design of insulators for DC specific stresses.

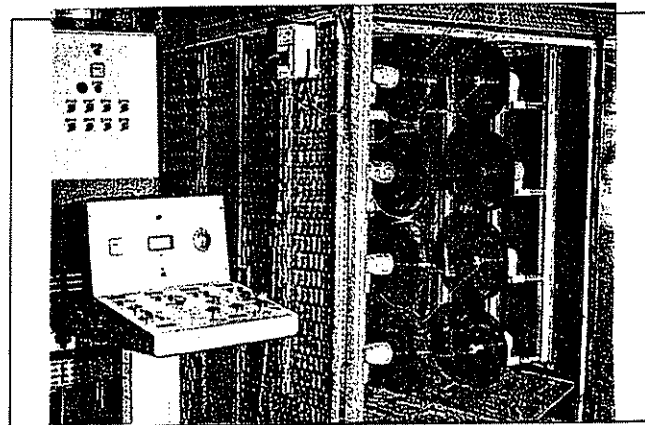

Figure 8 - DC thermal runaway test

#### 4.2 Evaluation of the performance of the toughened glass insulator after many years of operation on the lines

The previous data on the service experience of the Sediver Toughened Glass insulators show no ageing effects.

Toughened glass insulators are not subject to ageing. This is also confirmed by the comparison of the test results on new and aged insulators removed from the lines.

#### 4.3 Conclusion

The inspection cost of toughened glass insulator string is in order of 2,5 US dollars per tower in comparison of 400 US dollars for porcelain insulator string for which a consumed Lime and complicated operations are required (buzzing, control of the electrical field, others diagnostic methods)

SEDIVER-ELECTROVIDRO toughened glass insulators have a very low rate of shattering in service, less 10 times of the other toughened glass insulators.

#### 5. Criteria of the selection of the insulators for overhead lines for AC and DC applications

The choice of the insulators must be made with consideration of :

1. The characteristics of the electrical network itself ;
2. The environment in which the line will have to operate (thunderstorms, winds, ice, pollution, etc...)
3. The degree of reliability required
4. The effects of ageing on the characteristics of the insulators.

The standardisation work carried out over the last 40 years has led to the development of many IEC and ANSI standards for toughened glass and ceramic insulators [12, 13, 14].



BRAZILIAN WG-22.03

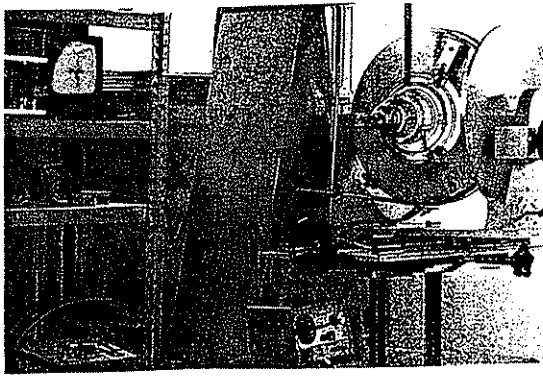

Fig. 7 - Measurement of the external compressive pre-stresses imparted by the toughening process

- An indentation machine was developed to measure and to control the toughening stresses in various points of a glass shell for all shapes (see figure 7). A software is also developed.

### 3.2.1.2 Thermal shocks on the Toughened glass shell :

Sediver has developed a series of particular thermal shocks which are applied to the glass shells before their assembly. These routine tests are applied to each shell on the production line to control the toughening quality and the purity of the glass. In this way all pieces which contain harmful inclusions are eliminated by these appropriate thermal treatments.

### 3.2.2 Insulator assembly

After manufacture and control of the glass shells, they are assembled with their caps and pins. The assembly is done using an alumina cement mortar which has a very high strength and is chemically inert and not subject to ageing when it is correctly prepared.

This automatic assembly process includes the fitting of the split-pin and the routine mechanical strength test at 50% of the guaranteed failing load.

### 3.3 Quality Control:

Throughout the manufacturing process, the insulators and their components are checked by the Quality Control department using unitary and sample tests.

In addition, the Quality Assurance department ensures that the product and process are in agreement with the requirements of world quality assurance specifications (ISO 9001). It is ensured that :

- The finished product corresponds to specification,
- Internal procedures are followed in the case of :
  - supply of components
  - fabrication,
  - tests,
  - controls,

- Corrective measures are applied in case of discrepancies,
- Test equipment is always calibrated.

Sediver's QA programme complies with ISO 9001 and CAN. Z299.2.

## 4 Field experience

### 4.1 Reliability of toughened glass insulators on overhead lines

The evaluation of the service experience of the insulator can be calculated from the numbers of failures in time which do or do not affect the operation of the line.

It is often very difficult to separate the different causes of the failure such as :

- Internal causes due to an internal defect in the insulator, poor quality of the material, manufacturing process or poor design,
- External causes such as vandalism.

For porcelain insulators, the main "internal" causes of failure are due to environmental stresses (thermal, mechanical, lightning ...) and are not easy to detect on the line. It is necessary to check each individual unit to detect cracks [6].

On the contrary, for toughened glass insulators, each harmful defect will lead to complete shattering of the skirt, which can be detected easily by a visual inspection from the ground or helicopter.

For this reason, much precise data [1, 2] are available only for toughened glass insulators.

Different utilities have reported annual statistics on the failure rate of toughened glass insulators.

The data shows that the failure rate :

- Depends on the manufacturer,
- Varies with time. The failure rate is generally higher the first three years before decreasing. This is contrary to porcelain insulators for which the ageing mechanism is such that the failure rate increases with time.

### 4.1.1 Data on the performance of toughened glass insulator developed in France on AC lines

- Sediver Electrovidro Toughened Glass insulators are used on AC lines up to 800 kV



### 3.2 Toughened glass insulator technology

#### 3.2.1 Glass shell manufacturing

##### 3.2.1.1 Toughened glass process

Mineral insulating materials, glass and porcelain, have a very high intrinsic mechanical strength (2000 MPa for glass), but they are brittle. Therefore (see the chapter 3.1.4.1) their mechanical strength is determined by the micro-defects which exist at the interfaces (external or internal). These micro-defects are inevitable, uncontrollable, and limit the practical mechanical strength to a few tens of MPa, when, in time, they do not lead to a critical degradation of the part.

The cracks which appear in window panes of annealed glass or domestic porcelain and which grow without apparent reason are well known; similar phenomena occur in porcelain or annealed glass insulators; they are found each time batches of such insulators are checked several years after manufacture. These defects are dangerous in that they can provoke the complete failure of the insulator and line drop when a power arc occurs.

Such incidents, whose rate of occurrence is normally low and considered normal by the line maintenance personnel, are often ignored by the central administration of electric companies, until the day when such an incident has such dramatic economic or human consequences that public enquiries are made.

For a material to be able to be effectively toughened, it is necessary that, during cooling, the resulting structural modifications which occur bring about a progressive increase of the viscosity, a continuous reduction of the volume and a marked decrease in the coefficient of expansion at the moment of solidification

Crystalline materials (such as porcelain) do not have such characteristics so they cannot be toughened. On the other hand, amorphous materials, in which stress relaxation is sufficiently slow at ambient temperatures, can be toughened.

In fact, glass is the only material having all the necessary characteristics, including a viscous stress relaxation speed at ambient temperatures which is nil in the scale of a human life-span. The creation of a permanent stress system inside a glass object with compression of the outer layers balanced by extension of the inner layers is obtained by rapidly cooling the surface of the object.

To toughen glass insulator shells, fast cooling is obtained by blasting cold air, dosed and directed by carefully positioned compressed air jets. The stresses result from the variation of the temperature gradients in an material which passes while cooling from the molten to the solid state through an intermediate visco-elastic state.

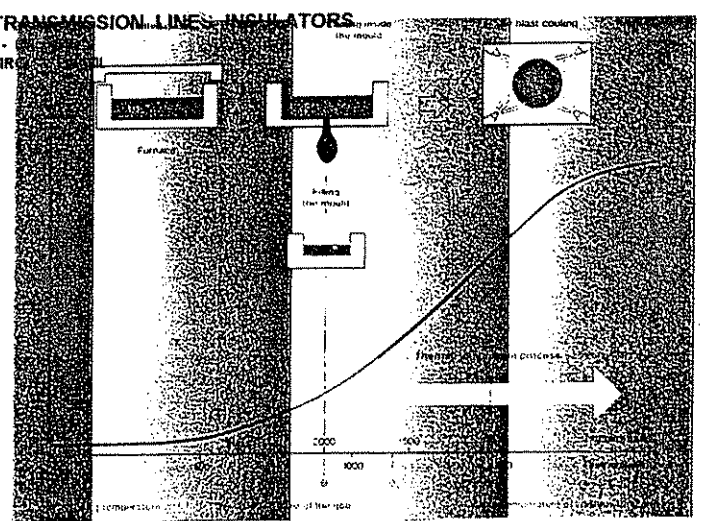

Fig. 6 - Principle of toughening process

Variations of the viscosity of glass as a function of the temperature

In ceramic materials such as porcelain and glass, the presence (or absence) of internal discontinuities is extremely significant. This is because of the many microcracks which may form at these locations during processing and which, under the mechanical stresses produced by service conditions, will propagate with time and ultimately lead to breakage. In short, the presence and propagation of internal microcracks is a major reason why porcelain insulators lose strength with age.

Under electrical stresses particularly those whose which result from voltage impulses due to lightning and switching surges, a breakdown process originates at points of structural irregularity in insulator dielectric shells. Thermal effects then take place, and lead to eventual puncture.

Under thermomechanical stresses, a crack can be developed from a microcrack, leading to electrical puncture and mechanical failure. Microcracks at the surface of ceramic dielectric shell materials have an equally important effect on the mechanical and electrical performance of suspension insulators due to the intense concentration of stress which occurs at critical surface cracks and which causes propagation leading to eventual failure [6]. Since surface microcracks are inherent to such materials as glass and porcelain, some form of compensation or control over this condition is necessary. The methods used to overcome the effects of surface microcracks are :

- In toughened glass insulators permanent compressive pre-stresses are imparted into the surface region of glass dielectric shells by the controlled cooling process known as toughening. Because the compressive pre-stress is substantial (250 Mpa, 35,000 psi) the formation and propagation of surface microcracks is very strongly inhibited and this is the reason why toughened glass insulators endure the brutal conditions of overhead line service [7].

Moreover the proximity of the sea can add saline pollution to the parameters needed to define the appropriate insulator string [15, 16].

To prevent problems due to a significant leakage current and associated arcs on the surface of the dielectric, the insulators must be protected against corrosion effects. A reinforced galvanising is recommended for the metal parts of the insulators. In tropical polluted areas, as defined above, a sacrificial pure zinc sleeve is necessary of prevent the corrosion of the pin and appropriate hardware can be added to obtain a better voltage distribution along the string during the wetting and drying periods to reduce the rac activity.

The basic standards tests as defined above are applicable to the insulators with these improvements for a reliable service in tropical environment [17].

#### 5.4.1 Electrical design aspects of the transmission line for insulator design :

The following points must be born in mind when designing transmission lines.

- Economics
 

The most efficient use of creepage path by judicious choice of the insulators can reduce string length. The resulting reduction in tower height and right of way can give economies of 15 to 40% of the line cost. [18]

The reliability, ease of maintenance, and easy live-line washing of toughened glass insulators result in significant savings in line operation costs.
- Insulation co-ordination
  - \* switching  $U > 300$  kV
  - \* lightning  $U \leq 300$  kV
- Other electrical considerations
  - \* RIV [19]
  - \* Power arc
- Other mechanical considerations
  - \* Wind +Ice
- Environmental considerations
  - \* Pollution (natural and industrial)
  - \* Altitude

#### 5.4.2. Basic tests and standards

- IEC 383-1 and 2
 

These two standards give a minimum quality and design requirement for insulator units and strings
- IEC 1211
 

This standard replaces the power frequency puncture test in oil by a steep front wave test which ensures that the insulator materials and design are of sufficiently high quality to give trouble free operation, especially in areas of high thunderstorm activity.

- IEC 437
 

This standard gives radio-interference tests for insulator units, this is imperative for any line passing near or through inhabited areas.
- IEC 1467 Tr2
 

This standard on power arc tests is described above in § 5.3.

#### 5.4.3 Necessary requirements for the insulator design and materials

- Cement
 

An alumina cement is recommended to avoid any risks of "cement growth" which can occur in humid environments [20]
- Metalwork
 

The metal fittings of line insulators are normally made of cast iron (caps) or forged steel (pins). It should be noted that a well designed insulator fails by fracture of a metal part ; the effects of fatigue on metals are well known and can be easily taken into account in the design. However, severe corrosion can reduce their strength considerably. So, when the problem appears it is more important for the pin. Special protection such as a zinc sleeve may solve this problem

A final point which concerns the effect of power arcs (melting of metal fittings). It is clear that the mechanical behaviour depends on the size and the design of hardware (horns, rings, ...) and their relative position versus the bottom insulators.

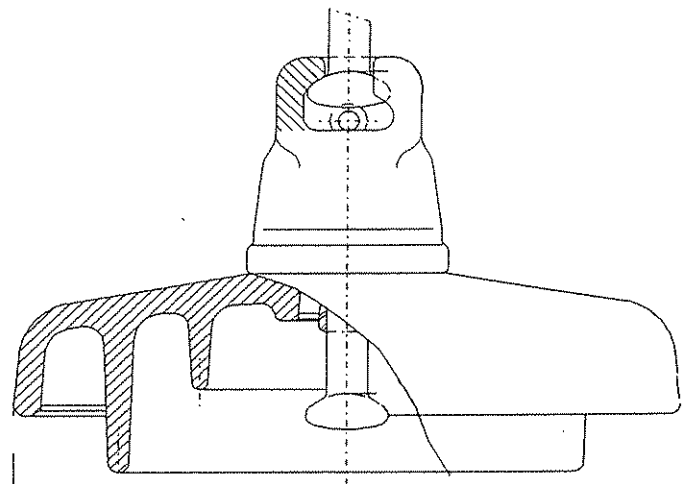

Fig. 10 - Corrosion retardation ring

- Locking Device
 

The locking device of cap and pin insulators is either a special split pin or a W-clip. The split pin is to be preferred for its ease of maintenance during live-line working.
- Coupling type
 

The ball and socket coupling is the most widely used type. Clevis and tongue couplings have a movement which is limited to one plane and can therefore cause bending and damage of fittings when the string is lifted to the tower or during conductor stringing.





BRAZILIAN WG-22.03

6 **CONCLUSION - The advantages of SEDIVER ELECTROVIDRO toughened glass insulators**

More than 350 millions of insulators developed in France are operating successfully in service in all conditions including on AC and DC overhead lines :

- Reliability : proven by successful compliance to the strictest standards and tests (Thermal mechanical test, steep front wave test and long term performance in service),
- High creepage path to spacing ratio allowing optimal use of string length,
- Corrosion protection of the pin available for extreme environmental conditions,
- Good power arc resistance
- Even when damaged the resulting stub maintains at least 80% of the original guaranteed strength,
- Easy maintenance and live-line working,
- Different profiles adapted to different types of pollution,
- All profiles optimised to reduce wind noise,
- Low radio interference and audible noise.

| Composition ●                                                                                                                                           | Manufacturing ■                                                                                                                                                                                                                                                                            | Routine control test ◆                                                                                                                                                            |
|---------------------------------------------------------------------------------------------------------------------------------------------------------|--------------------------------------------------------------------------------------------------------------------------------------------------------------------------------------------------------------------------------------------------------------------------------------------|-----------------------------------------------------------------------------------------------------------------------------------------------------------------------------------|
| <ul style="list-style-type: none"> <li>● Automatic control of composition</li> <li>● Standard glass</li> <li>● D.C. Glass higher resistivity</li> </ul> | <ul style="list-style-type: none"> <li>■ Selection of the raw materials</li> <li>■ Reduction of inclusions</li> <li>■ Oven technology (refractories)</li> <li>■ Rel.Nocivity of inclusions</li> <li>Laser Detection Quantitive Qualitative</li> <li>◆ Elimination of inclusions</li> </ul> | <ul style="list-style-type: none"> <li>◆ New approach to thermal shocks</li> <li>◆ Automatic inspection of glass shells</li> <li>◆ More reliability on visual controls</li> </ul> |

Fig 11 - Review of process and control improvements of glass shell

| Toughening ○                                                                                                                  | Cement □                                                                                                                                 | Component shell cap, pin ◆                                                                                                        |
|-------------------------------------------------------------------------------------------------------------------------------|------------------------------------------------------------------------------------------------------------------------------------------|-----------------------------------------------------------------------------------------------------------------------------------|
| <ul style="list-style-type: none"> <li>○ Better knowledge of toughening stresses</li> <li>Identification equipment</li> </ul> | <ul style="list-style-type: none"> <li>□ Tight preparation control</li> <li>Extra high mech. strength</li> <li>No degradation</li> </ul> | <ul style="list-style-type: none"> <li>◆ Shell</li> <li>Improved profile for pollution</li> <li>◆ Cap &amp; pin better</li> </ul> |

|                                                                       |                                                                                                                                                   |                                                |
|-----------------------------------------------------------------------|---------------------------------------------------------------------------------------------------------------------------------------------------|------------------------------------------------|
| Software<br>○ Computation & computer model of internal shell stresses | <input type="checkbox"/> Cement assessment<br>Intensive to thermal shock<br>Long term use of aluminous cement control over dispersion of strength | For stress dist.<br>◆ Zinc ring on cap and pin |
|-----------------------------------------------------------------------|---------------------------------------------------------------------------------------------------------------------------------------------------|------------------------------------------------|

Fig. 12 - Review of the component improvements of the insulator

SEDIVER has always been a pioneer and a leader in the field of insulator research and development. The toughened glass insulator is the fruit of long term studies to produce insulators with:

- High and reliable mechanical performance for AC and DC lines requiring insulators with failing loads up to 530 kN : very low maintenance costs due to the low failure rates in service by eliminating harmful inclusions before and during the manufacturing process.
- Glass dielectrics adapted to the most severe environmental conditions with shapes and profiles for all different types of pollution for the different climates.
- In house production of metal fittings

The reliability of the toughened glass insulators developed in France and extended to other plants of the group is validated by a service experience since fifty years on more than 350 millions units used in more than 120 countries around the world on overhead lines respectively up to 800 kV AC and 600 kV DC.

More than one out of four toughened glass insulators are in operation in polluted areas (natural, industrial and mixed pollution ...).

In all severe conditions including heavy pollution, the key factors of the success of the toughened glass insulators developed in France are :

- high mechanical and electrical performance
- no ageing
- no hidden defect
- and low cost for the maintenance.

## REFERENCES

- [1] Cigre 97 - panel 3.04 "Reliability of insulators for overhead lines" by A. CIMADOR/J. LAPEYRE/R. PARRAUD/C. DE TOURREIL On behalf of study committee 22
- [2] "Statistics for porcelain and glass insulators" ELECTRA Vol. 153, April 1994, pp 23-31
- [3] "Les verres en électrotechnique" by JC BRETON/D.RIVIERE/R.PARRAUD Techniques de l'ingénieur D240
- [4] IEEE BANGKOK 1985 CEPSI  
"Lightning stresses on overhead lines" by R.PARRAUD/C.LUMB
- [5] CIGRE 33.07.01 - ELECTRA 991 - "Essais de perforation des isolateurs verre et céramique" by M.ARO/R.JOULIE/A.BAKER/G.TREVISAN/K.NAITO/Z.LODI
- [6] IEEE WG INSUL.STRUNGTH RATING/1987  
"Reflexions on the evaluation of the long term reliability of ceramic insulators" by R.PARRAUD/C.LUMB/JP.SARDIN
- [7] 14 INT.CONGRESS ON GLASS/1987 "Thermal tempering study of glass insulators by means of a finite element modelisation" by D.DUMORA/H.SAISSE/B.KNOSP/J.GOUDEAU/C.L. ICHT
- [8] Canadian Electrical Association, Spring meeting March 1990, "Performance of porcelain insulators : forty years of experience at Hydro-Québec" by JP. BELLERIVE
- [9] "Insulator news and ??? report" July/August 1995 - Vol. 3 Number 4 Pages 23-29 by R. MARTIN
- [10] CIGRE September 1991 - Colloquium on HVDC New Delhi "State-of-the-art concepts of insulation strings for HVDC lines" by D. DUMORA/L. PARGAMIN/R. PARRAUD
- [11] CIGRE SC 33 Colloquium New Delhi N°2.12/1993  
"Field experience of HVDC toughened glass insulators by R.PARRAUD/C. LUMB
- [12] IEC 383 Insulators for overhead lines with a nominal voltage above 1000 V
- 383-1 Part 1 : Glass or ceramic insulator units for a.c. systems  
- Definitions, test methods and acceptance criteria (1993)
- 383-1 Part 2 : Insulator strings and insulator sets for a.c. systems  
- Definitions, test methods and acceptance criteria (1993)
- [13] ANSI C29.1 : American National Standard for Electrical Power insulators - Test methods (1988)
- [14] ANSI C29.2 : American National Standard for insulators ( Wet process procelain and toughened glass - suspension type (1992)
- [15] SEE 1990 "Station d'essai pour l'étude du comportement des isolateurs sous très forte pollution" by C.LUMB/S.BLETTERY/R.JOULIE/R. PARRAUD
- [16] "Long term reliability of toughened glass insulators for overhead lines" by R.PARRAUD/D.DUMORA ( 1st Magarebi symposium Tripoli
- [17] Insulator design suits Moroccan desert by S.WRIGHT  
- Electric power international
- [18] ISPPID/1981 "consideration on the choice of insulators for polluted areas" by R. PARRAUD
- [19] CIGRE STOCKHOLM/1981 "Perturbations radio-électriques engendrées par les chaines d'isolateurs: valeurs limites et conception des chaines" by C.GARY/D. RIVIERE/R.PARRAUD
- [20] IEEE PAS 136-9-3 "Cement growth failure procelain suspension insulators" by E.CHERNEY